



WWW.MABI.FR

POMPE HP MEMBRANE

Instruction manual



MABI SARL ZAC DES SAULES BP 27 90400 BOTANS
FRANCE
TEL:+33 3 84 56 17 44 bidaux@mabi.fr



Référence :
PHPMEMBRANE
Indice : A
Date 04/12/17

Introduction

Dear customer,

Thank you for choosing our product. Please read this manual carefully before using the spraying pump.

This instruction manual has been drawn up by the manufacturer and it is an integral part of the product supplied. All the information that it provides is addressed either to unqualified (that is to say unskilled) or to highly qualified personnel.

This instruction manual makes clear the intended purpose of the pump and contains all the information needed to ensure its safe and correct installing and use.

Further technical information that might not be contained in this instruction manual can be found in a technical file drawn up by **MABI** and which is available for consultation at its offices.

Consult carefully this instruction manual before proceeding to installation, use or any intervention on the pump.

A constant observance of the regulations it contains ensures both the operator and the pump's safety, the working economy and a longer working life to the pump. While designing and realizing this pump we have respected all the standards and dispositions needed to meet the basic safety requirements provided for by the European community regulations.

The careful analyzing of risks made by **MABI** has ensured the elimination of the most part of them; however it is recommended to keep strictly to the instructions contained in this instruction manual. Never fail to consult this manual before accomplishing any operation.

Preserve this manual with care and try to place it close to the pump or not too far from it so that it can be easily found for consultation.

Schemes and charts are supplied with an exemplifying purpose; the manufacturer, in his pursuit of a strategy for the constant development and updating of this product, might make changes in it without any notice.

This instruction manual must be preserved during the pump's whole lifetime; in case of loss or destruction you should ask for a copy from the manufacturer specifying its identification data (the price will be fixed by the manufacturer). If the pump is sold to outside parties, the manufacturer has to be informed (through written communication) of the name and address of the new user.

MABI will take care of informing its customers of any modification concerning the **SAFETY REGULATIONS** of the pump.

Every suggestion from the customers concerning improvements to apply to our pump will be welcomed: **MABI** will surely analyze the possibility of realizing them.

MABI claims the absolute right of ownership on this document: it is forbidden to disclose it, either totally or partially, to a third party without written authorization by **MABI**.

The pump is also supplied with:

- **Declaration of conformity**
- **WARRANTY:** (*see chapter at the end of the manual*)

Note: All right reserved, including those of translation. No part of this work may be reproduced by any means or used in any form without the permission of MABI

Note: All drawings and all informations container herewith are confidential. It is the sole property of MABI, extended shelf life division. No reproduction in any manner written or verbal is allowed without expressed written approval of MABI.

DECLARATION OF CONFORMITY

MABI

Model:.....

Serial number:.....

which this declaration refers to, conforms to
the provisions of the law governing machinery directives:
89/392/CEE, 91/368/CEE, 93/44/CEE, 93/68/CEE, 72/23/CEE, 89/336/CEE.

INDICE

<i>Introduction</i>	<i>1</i>
<i>DECLARATION OF CONFORMITY</i>	<i>4</i>
<i>INDICE</i>	<i>5</i>
1. HOW TO EMPLOY AND PRESERVE THIS INSTRUCTION MANUAL	7
1.1 To whom this instruction manual is addressed	7
1.2 Purpose of the information contained in this instruction manual	7
1.3 Limits of use of the instruction manual	7
1.4 How to preserve your instruction manual	7
1.5 Symbols used in the user manual	8
2 TECHNICAL DATA	9
3 TRANSPORTATION OF THE PUMP	10
3.1 On receipt of the pump	10
3.2 Unloading operations of the pump	10
3.3 Unpacking	11
4. MARKING DATA	12
4.1. Marking data of the pump	12
4.1.1 Serial number of the pump	12
4.1.2 CE Mark	13
5. TECHNICAL DESCRIPTION OF THE PUMP	14
5.1 Description of the main components	14
5.1.1 Trolley	15
5.1.2 Pressure gauge	15
5.1.3 Pressure regulator (1 Fig. 6)	15
5.1.4 Accumulator	16
5.1.5 Pump casing	16
5.1.6 Discharge tap	16
5.1.7 Suction pipe	17
5.1.8 Spray gun (optional)	17
6. ASSEMBLY OF THE PUMP	18
6.1. Generalities	18
6.2. Assembly steps	18
7. INTENDED USE OF THE PUMP	20
7.1 What is the machine used for	20
7.2 Intended purpose of the pump	21
7.3 Safety precautions	22
7.3.1 Safety regulations for use	22

7.4	Incorrect use of the pump	26
7.4.1	Transfers	28
7.4.2	Requirements of the operator.....	29
7.4.3	Requirements of the maintenance operators.....	30
7.5	Storage	31
8.	<i>MAINTENANCE</i>.....	32
8.1	Generalities.....	32
8.2	Security regulations in terms of maintenance.....	32
8.3	Classification of maintenance intervention	33
8.4	Cleaning of the pump	34
8.5	Cleaning of the spray gun	36
8.6	Oil change	38
8.7	Diagnosis of problems.....	39
9.	<i>TORQUE WRENCH SETTING OF SCREWS AND BOLTS</i>.....	41
	<i>Spare parts request form</i>	42
10.	<i>LIST OF SPARE PARTS</i>.....	43
10.1	Group – A1097080 (EXPORT 7000/10000 pump).....	43
10.2	Group – 012034C (2 HP general identification plate support).....	45
10.3	Group – A0197045 (stainless steel suction valve for electric pumps)	46
10.4	Group A0197046 (complete SM-EXPORT membrane).....	47
10.5	Group – 023003AC (EXPORT 7000 piston)	48
	Group – 033002AC (EXPORT 10000 piston)	48
10.6	Group – A0197048 (complete ¼ discharge tap)	49
10.7	Group – A0197051 (complete SM-EXPORT nonreturn valve).....	50
10.8	Group – 012007C (EXPORT pressure gauge)	51
10.9	Group – A0197047 (complete SM-EXPORT pressure regulation valve)	52
10.10	Group – C5502 (complete big trolley for electric pumps).....	53
11.	<i>WIRING DIAGRAM</i>	54
12.	<i>WARRANTY</i>	55

1. HOW TO EMPLOY AND PRESERVE THIS INSTRUCTION MANUAL

In this chapter we supply some information about the correct way of using this manual together with the fixed limits of use.

1.1 To whom this instruction manual is addressed

This manual is intended for the following users:

- transportation, loading and unloading personnel
- operators
- installers
- maintenance personnel.

1.2 Purpose of the information contained in this instruction manual

The instruction manual explains how to employ the pump according to the project; it supplies the technical characteristics, the instructions for the removal, transportation, installing, regulating and use; it gives advice for the maintenance operations and for ordering the spare parts.

1.3 Limits of use of the instruction manual

Users are reminded that this manual can never replace the necessary experience of the operator and that it can be only a reminder of the main operations to be executed. Furthermore, we want to remind that it reflects the technical achievements at the moment of the purchase and that the manufacturer has the right of updating either the manual or the equipment without making changes, with a few exceptions, to previous manuals and products.



1.4 How to preserve your instruction manual

We remind users that the manual has to be carefully preserved to ensure it to last as long as the pump. For this purpose it is provided with a suitable case to protect it from wear and tear.

The section concerning the transportation of the pump is supplied in two copies so as to allow the transporter and the personnel in charge of unloading operations to consult their own copy without recurring to the original.

In case of loss or destruction of the manual, you can ask for a copy addressing your request to the area agent or to the manufacturer specifying model, serial number and year of production of the machine.

1.5 Symbols used in the user manual

 WARNING	Description: This symbol highlights the special indications which may bring about physical harm to people or may jeopardize human life if not strictly complied with.
 CAUTION	Description: This symbol highlights the special indications which may cause damage to things or may even destroy the pump if not strictly complied with.

2 TECHNICAL DATA

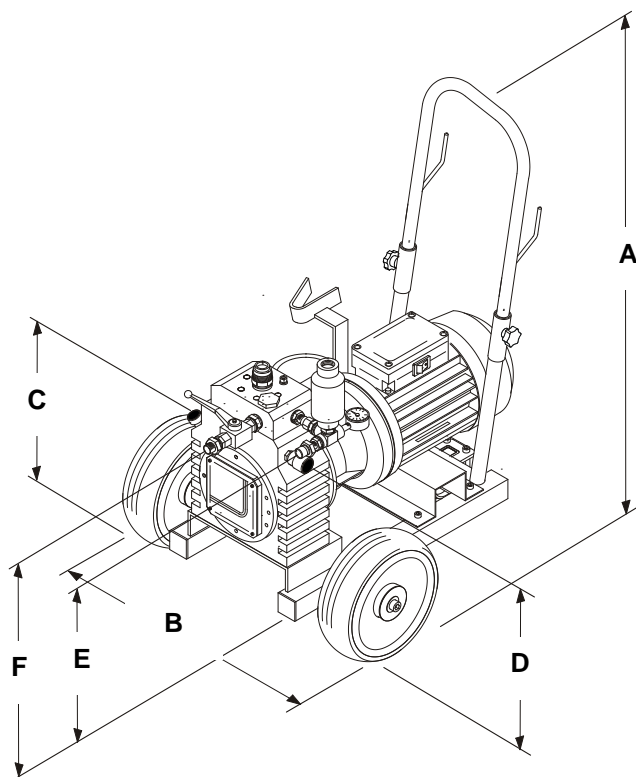

A).....860 mm D).....460 mm
 B).....500 mm E).....460 mm
 C).....400 mm F).....480 mm

SPRAYING PUMP		
	Model	
Technical Data	EXPORT 10000	EXPORT 7000
Flow (l/min.)	10	7
Compression ratio	---	---
Max product pressure (bar)	250	250
Pump casing weight without trolley (Kg.)	55	54
Level of noise (dB) (A)	70	70
Installed power (kW)	1,9/2,5	1,5

3 TRANSPORTATION OF THE PUMP

In this chapter we supply all the necessary directions to accomplish correctly the operations of loading-unloading, transportation and installing of the pump.

3.1 On receipt of the pump

The pump, depending on the needs, is sent as follows:

- A) In a cardboard box
- B) In a common case internally coated with tar paper.
- C) The same as in B added with a protective vacuum sealed packing (barrier bag) for shipment.

The choice among the above mentioned alternatives depends on the length of the transportation, on the customer's instructions and on the amount of time the pump has to remain packed up.

In packing B) and C), on the four sides of the case the following data are paint-written:

- Destination
- Contract number
- Weights: net - gross - tare
- Dimensions : length - width - height
- Copy of the packing-list (if present inside the case).

3.2 Unloading operations of the pump

The orientation of the cased pump has to conform to the indications given by the picture-writings and inscriptions found on the outer side of the casing (fig. 1).



Any damage to the pump provoked by wrong dislocation movements are not under WARRANTY.

 <p style="text-align: center;">YES YES</p>	<p>Standard packaging: Cardboard box</p>
 <p style="text-align: center;">NO NO</p>	<p>NEVER place more than 2 boxes containing the pumps on top of each other. Check the contents of the packaging if there are signs of damages.</p>
	<p>Temporary or extended storage must be carried out in closed environments away from atmospheric agents and the pumps must be handled with care.</p>

Fig.1

3.3 Unpacking

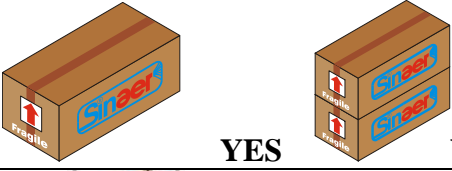
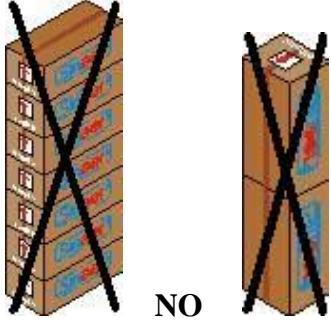
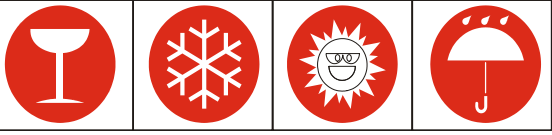

All of the materials used for packaging can be recycled and must be disposed off in compliance with local legislative regulations. Make sure that all plastic components are carefully disposed of to avoid the creation of sources of danger (suffocation) for children.

4. MARKING DATA

4.1. Marking data of the pump

Upon reception of the pump it is very **IMPORTANT** to read carefully all indications on the plate and the **declaration of conformity**. Any problems encountered in compliance with the order, must be immediately transmitted to **MABI**, before proceeding with any operation whatsoever.

4.1.1 Serial number of the pump

Always refer to the serial number of the pump when technical assistance is required or when spare parts are ordered. Old models and recent models (which can only be identified by the serial number) may differ slightly, or a different measure may be necessary before carrying out any kind of technical assistance.

The identification plate of the pump can be found on the right hand side fixed to the flange, as illustrated in figure 2.

The following drawing indicates manufacturer details.



4.1.2. CE Mark



This stamp, to be found on the identification plate of the pump, together with the “Declaration of Compliance” certifies compliance of the pump in accordance with essential safety requirements (RES) defined by the Machines Directive 89/392/CEE, 73/23CEE, 91/368/CEE, 93/44CEE, 93/68CEE.

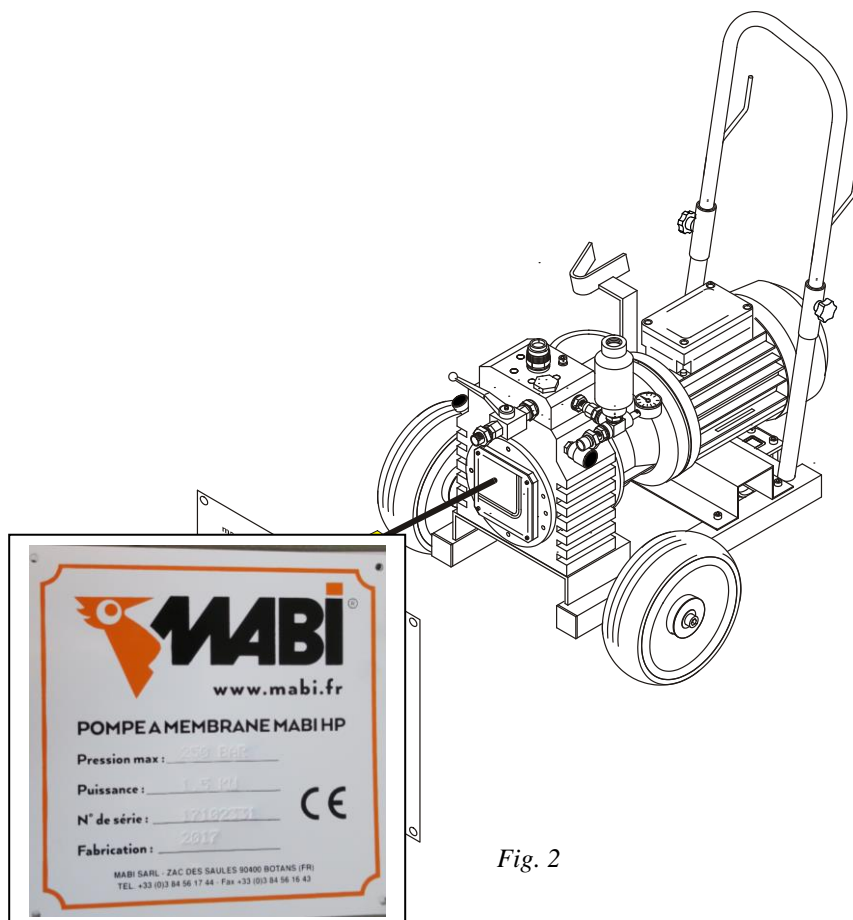

Fig. 2

5. TECHNICAL DESCRIPTION OF THE PUMP

In this chapter we provide a technical description of the machine and of the way it works; we will supply all the details that can be useful either to the operator or the maintenance personnel to understand its correct way of working and to find quickly any break-down or trouble.

5.1 Description of the main components

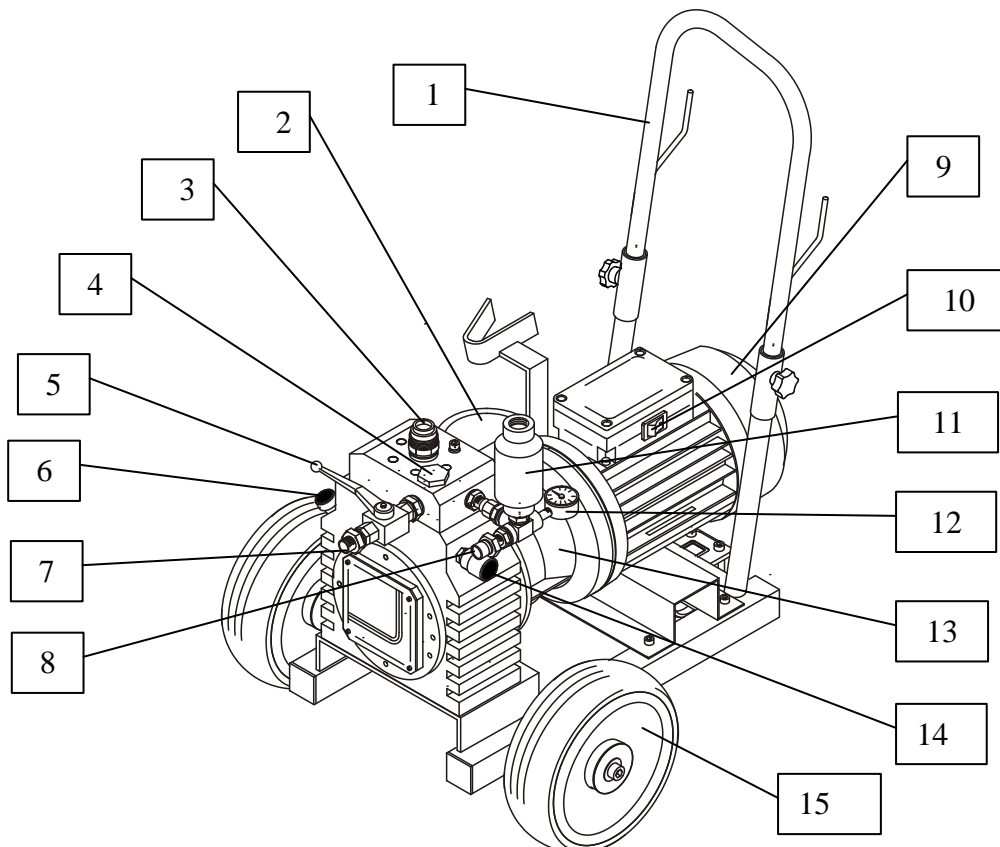

Fig. 3

- | | | | |
|---|---------------------------|----|--------------------|
| 1 | Trolley | 9 | Motor |
| 2 | Sieve support | 10 | Switch |
| 3 | Suction valve | 11 | Accumulator |
| 4 | Nonreturn valve cap | 12 | Pressure gauge |
| 5 | Discharge tap | 13 | Pump casing |
| 6 | Oil level cap | 14 | Pressure regulator |
| 7 | Discharge pipe connection | 15 | Wheel |
| 8 | Spray gun pipe connection | | |

Technical description of the pump

5.1.1 Trolley

The trolley, which is the supporting element of the entire machine is made from round and square tubular steel and is fitted with wheels to make movement of the pump fast and easy. The surfaces have been opportunely designed and treated to avoid the formation of rust and to guarantee a long lasting product.

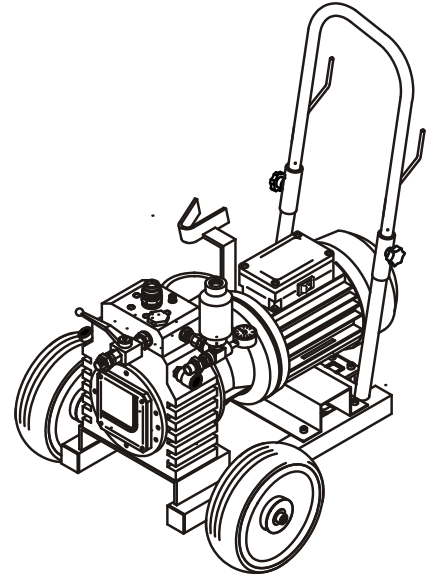

Fig. 4

5.1.2 Pressure gauge

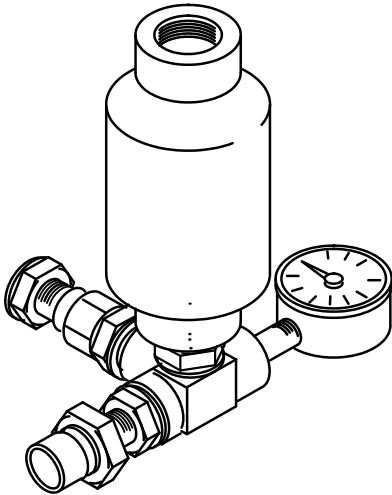

Fig. 5

The pressure gauge allows indication of the direct pressure to the spray gun.

5.1.3 Pressure regulator (1 Fig. 6)

The regulator allows control and regulation of the direct pressure to the spray gun. Regulate by turning the knob at the front of the hydraulic group of the pump.

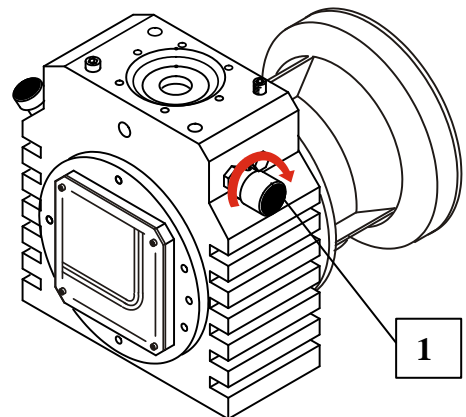

Fig. 6

5.1.4 Accumulator

The accumulator keeps the working pressure of the pump constant.

5.1.5 Pump casing

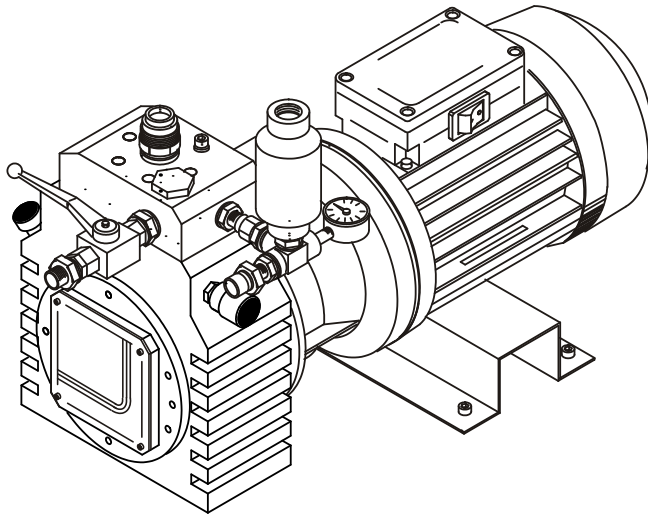

Fig. 8

The discharge tap allows you to discharge the air inside the pump before use.

1. Suction valve
2. Discharge tap
3. Discharge pipe connection
4. Nonreturn valve cap

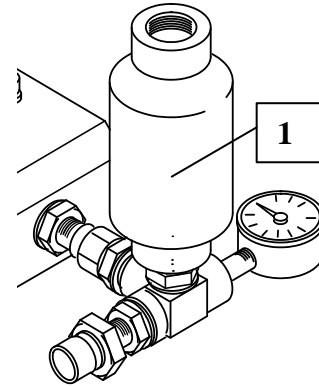

Fig. 7

The pump casing consists of the front hydraulic group and the motor at the back. A mechanical flange connects them and is kept in position by a series of screws.

5.1.6 Discharge tap

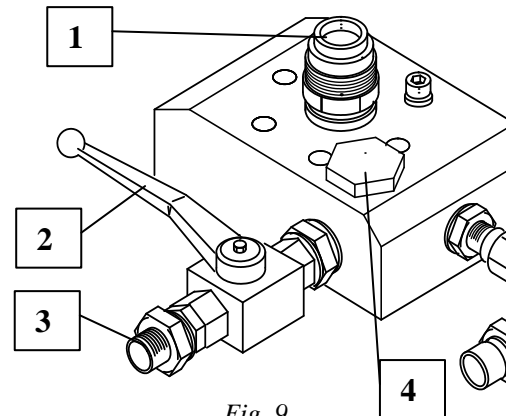

Fig. 9

5.1.7 Suction pipe

The pipe allows for suction of the product to be delivered right inside the pump. The end piece holds a filter that eliminates the largest impurities to be found in the product. It is connected to the lower manifold of the pump casing by a mechanical joint which can only be removed using a specific tool (41 mm. spanner).

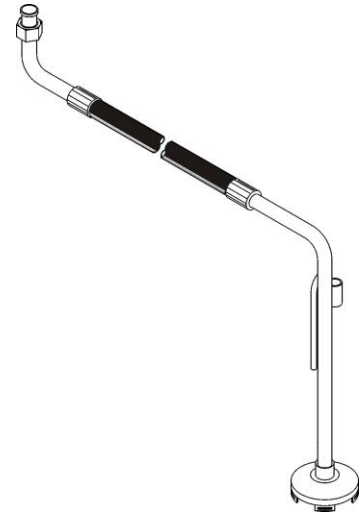

Fig. 10

5.1.8 Spray gun (optional)

An element that allows for the delivery and application of the product, it is fitted with a rapid attachment that is easy to handle.

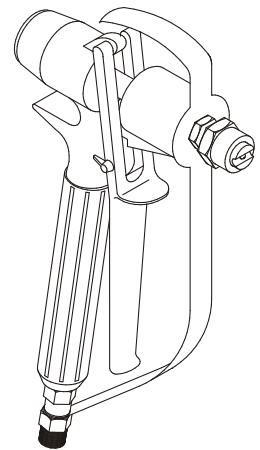

Fig. 11

6. ASSEMBLY OF THE PUMP

6.1. Generalities

This chapter provides all technical information necessary to carry out installation operations in compliance with current regulations.

Assembly and correct working of this product must be carried out by qualified personnel in compliance with the assembly instructions attached.

In the event of an incorrect assembly **MABI** declines any responsibility for damages to things and/or people.

6.2. Assembly steps

In order to carry out a correct assembly, carry out the following steps:

- 1 Remove the pump from its package making sure that the packaging is disposed of in compliance with local regulations with regards to waste disposal (fig. 12).

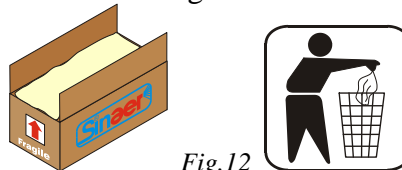

Fig.12

Check to make sure that the goods have not been damaged during transport and the pump has **NEVER** been used with elements damaged even partially (fig. 13).

The pump is already mounted on the trolley when packed, so when packaging is removed the suction system, delivery pipe, spray gun and nozzle must be connected.

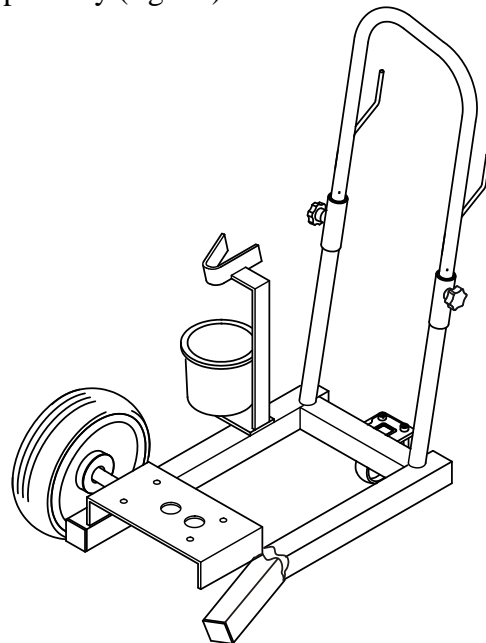
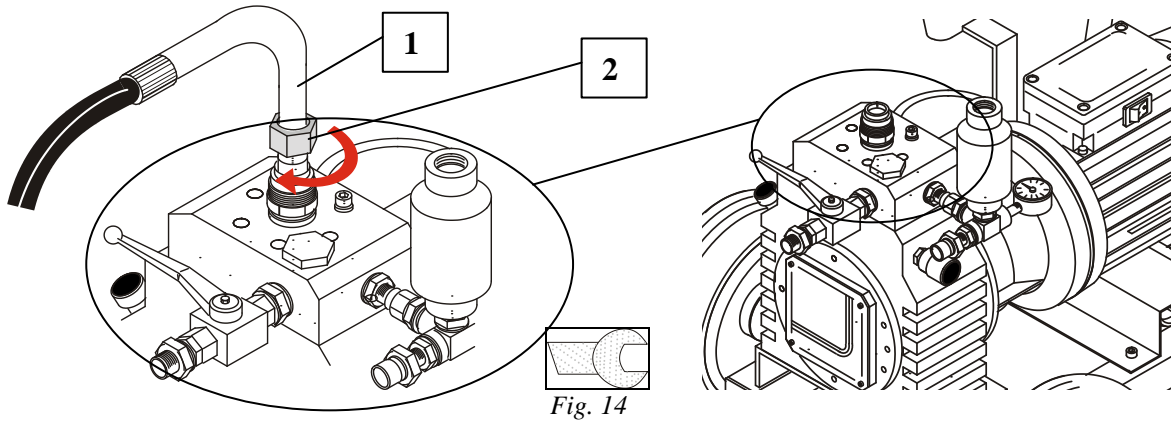

Fig.13

3 Fix the suction pipe to the pump casing using the relative suction valve joint. Screw down the joint using an open tool and check to make sure that it is fixed correctly (fig. 14).

1. Suction pipe
2. Joint



If the product leaks from the joint switch off the pump immediately.



Legend	
	Attachment that requires a tool
	Rapid attachment
	Screw attachment

4 Connect the pipe that brings the product delivered to the spray gun (fig. 15).

The pipe must be fixed using a screw joint, screw down using an open key.

5 Connect the discharge pipe to the tap and tighten with spanner (fig. 15).

1. Suction pipe
2. Discharge tap
3. Spray gun pipe
4. Discharge pipe

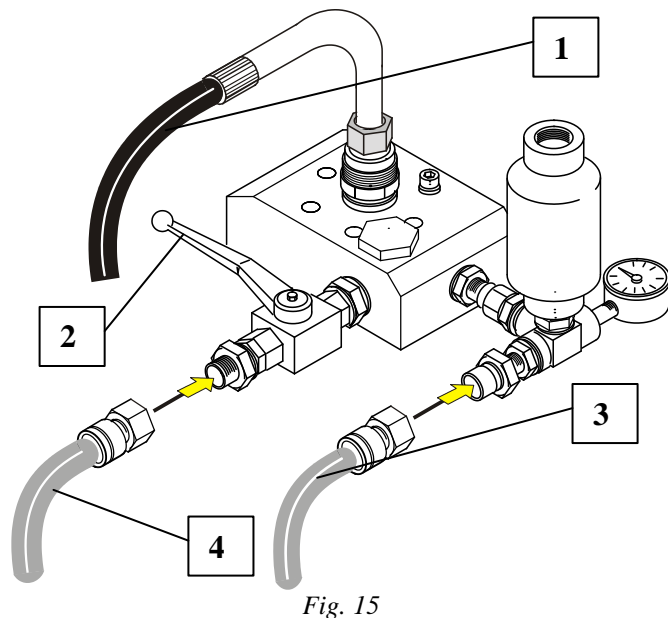

7. INTENDED USE OF THE PUMP

This chapter provides information of a general nature on the aims the pump was designed for, describing the main functions and limits of use.

7.1 What is the machine used for

MABI has designed and created a range of pumps used for painting large surface areas. The products that can be used with these kinds of pumps are normal paints which are very commonly used in manufacturing processes.

Special attention has been made and studies have been carried out with regards to safety systems for the operator as well as for the surrounding environment.



Any other use must be considered contrary to the applications provided for by the manufacturer and therefore the manufacturer will not be held responsible for any damages to external things or to the pump itself, nor damages to people caused by incorrect use of the machine.

Therefore we must point out that whoever carries out improper use of the machine will also be responsible for any other consequence.

Any change arbitrarily made to this pump exempts the manufacturer from any responsibility for damages or injuries. The manufacturer and all of the organizations operating in the distribution network, including all national, regional or local dealers, will be relieved from any responsibility for damages caused due to the incorrect operation of parts and/or components not approved by the manufacturer and used in the maintenance and/or repair of the product manufactured and sold by the manufacturer.

It is absolutely excluded that any kind of guarantee of any nature on the product manufactured by the manufacturer be granted for damages caused by incorrect operation of parts or components not approved by the manufacturer himself.

7.2 Intended purpose of the pump

The pump has been designed for industrial use and cannot be used for other reasons. An incorrect use of the pump may cause serious damages to the operator and/or to the environment in which they live, therefore the following are **strictly prohibited**:



- **To deliver high risk products to the pump such as explosives and/or corrosives or products not permitted by the manufacturer;**
- **To not comply with the user manual and maintenance instructions indicated in the present manual;**
- **The use of equipment and/or various components other than those provided by the manufacturer;**
- **The use of the pump in an incorrect manner and not in compliance with current regulations.**

7.3 Safety precautions

7.3.1 Safety regulations for use

The best operator is the most cautious one. The majority of accidents could be avoided if some precautions are observed.

In order to favor the prevention of accidents read and comply with the following precautions. The pump must be used only by those who are authorized and have been trained for its use.

In this manual when components are indicated reference is always made to whether they are on the left or right hand side of the pump.

In the majority of situations “**right**” and “**left**” mean in accordance with the operator placed in front of the pump (fig. 16), unless specifically indicated.

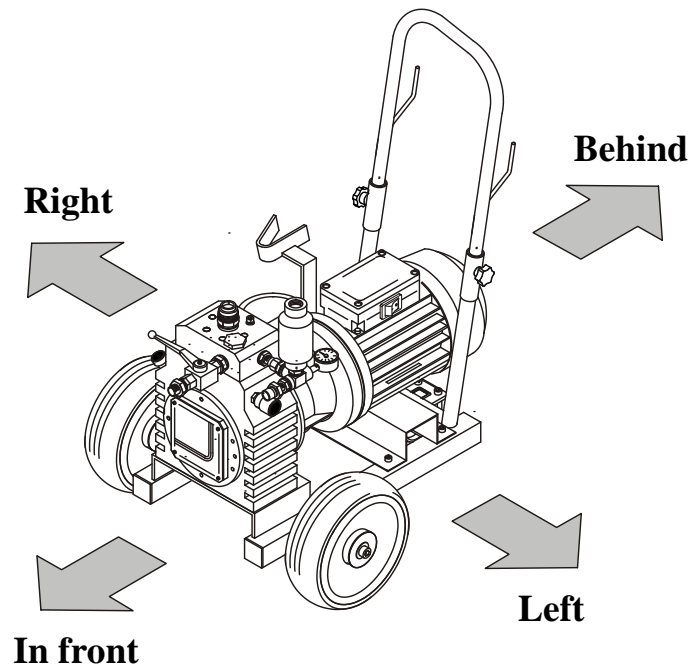

Fig. 16

Nobody should be allowed to use the pump without correct instructions.

In many countries it is obligatory that all operators are trained on the correct procedures for use of operation of the pump and safety methods before use (fig. 17).

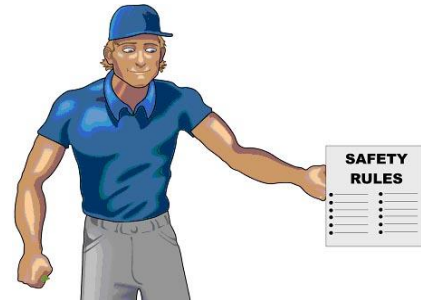

Fig.17



Fig.18

Read the user and maintenance manual carefully before using the pump (fig. 18). Ignorance of the regulations for use may cause accidents.

Make sure that every piece of equipment or accessory is installed correctly and that these pieces are approved for use on this type of machine.

- 1) Move the machine near to the area in which it should be used. Check to make sure that there are no people and/or things that may be run over during these stages.
- 2) Prepare all of the material required. Before plugging into the mains ensure that the voltage on the plate of the electric motor is the same as the mains supply.
- 3) Connect the spray gun to the pipe and tighten with spanner (fig. 19). Making sure that it is clean.

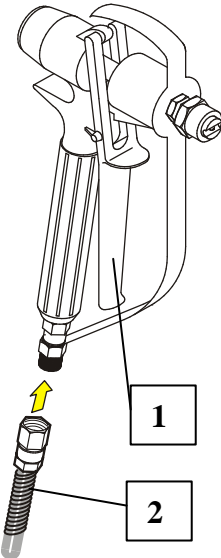

Fig.19

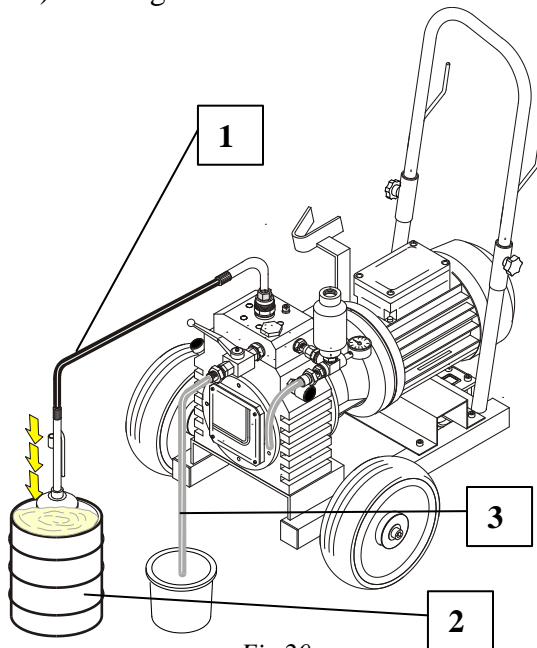
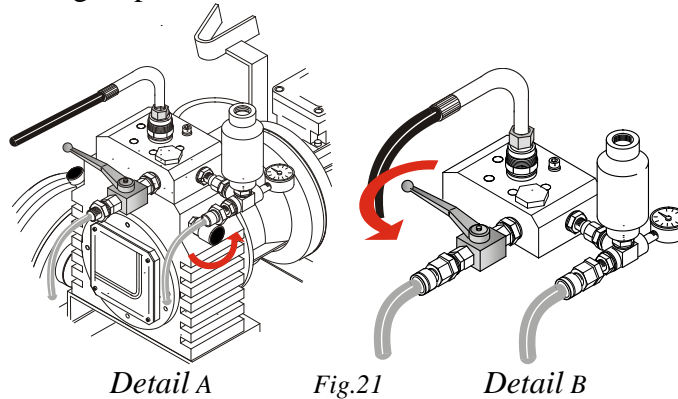

Fig.20

- 4) Insert the sieve ❶ into the container of the product to be delivered ❷ and insert the discharge pipe ❸ into the container to recover the paint. (fig. 20).

- 5) Adjust the pressure regulation valve to minimum by turning the tap clockwise (fig. 21, detail A).
- 6) Open the discharge tap to remove all of the air inside the circuit (fig. 21, detail B).



- 7) Start the pump motor with the ON/OFF switch (fig. 22).

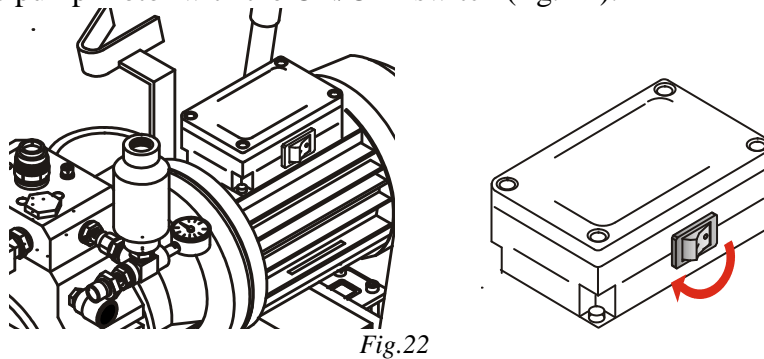

- 8) A few seconds after starting the motor the product will start to come out of the discharge pipe (fig. 23, detail A). The discharge of the product shows that all air has been expelled from the system. Close the discharge tap (fig. 23, detail B).

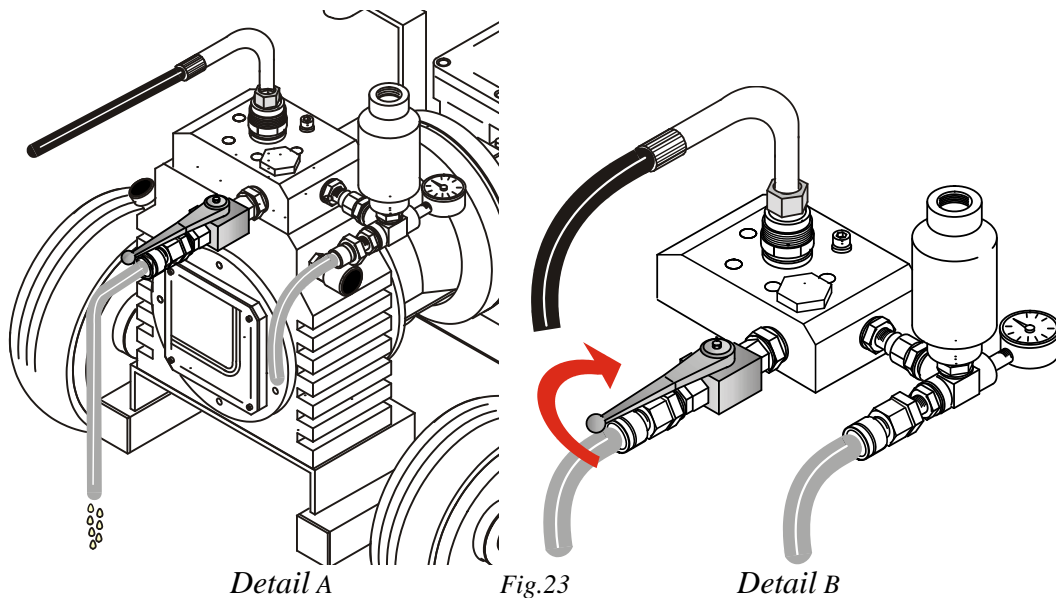

9) According to the viscosity of the product regulate the working pressure by rotating the regulator (0-250 bar) so that the pump can reach its own static pressure balance (fig. 24).

- Dense product, increase working pressure.
- Liquid product, decrease working pressure.

1. Pressure regulator
2. Pressure gauge

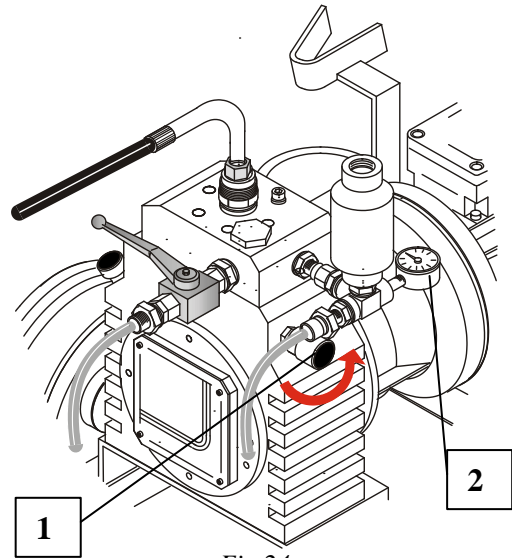

Fig.24

7.4 Incorrect use of the pump

We hereby provide some indications to be followed to avoid accidents during use of the pump.



1) Before starting the job place the pump in an area that will not obstruct the passage of machines and/or people.

2) Check to make sure that the pump is in a stable position to avoid it falling (fig. 25).

3) Check to make sure that all of the pipes are connected correctly (fig. 26)
In the event of an incorrect fixing **do not start the pump.**

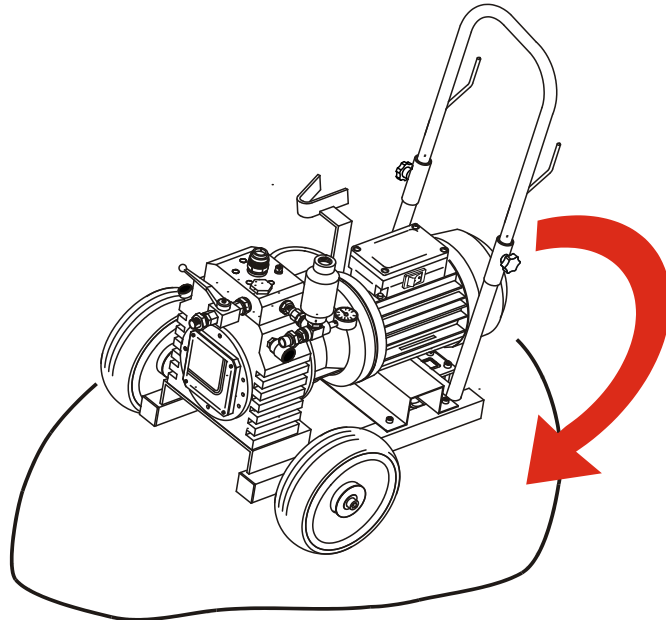

Fig.25

1. Suction pipe
2. Spray gun pipe
3. Discharge pipe

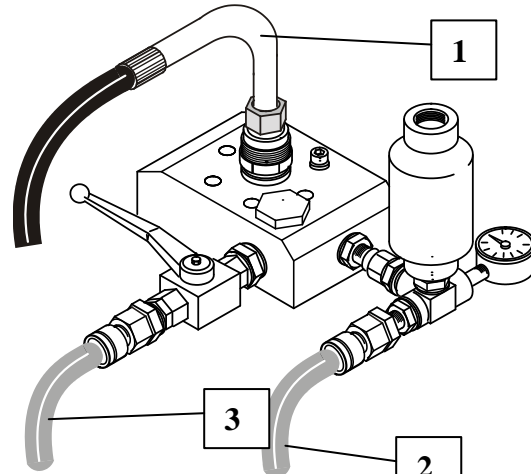

Fig.26

4) **NEVER** remove the product pipes while the machine is in operation (fig. 27).

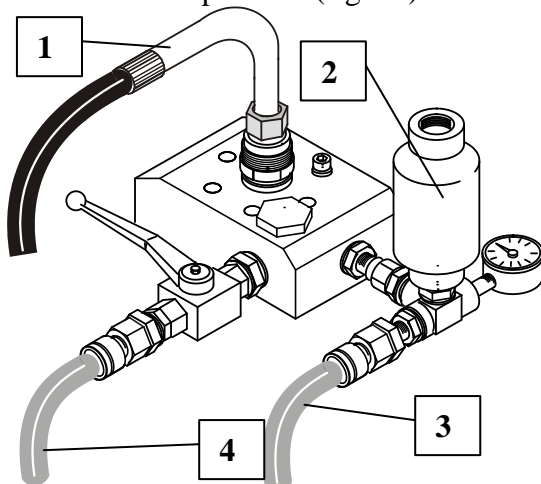

Fig.27

1. Suction pipe
2. Accumulator
3. Spray gun pipe
4. Discharge pipe

5) Use the pump in ventilated environments. The use of highly flammable materials must always be present therefore avoid contact with free flames or incandescent materials.

6) Always use individual safety devices in order to avoid poisoning or the contact of aggressive materials with parts of the casing.

7) The spray gun **MUST NEVER** be aimed at people (fig. 28) or objects that are not involved in the operations. Any kind of operation should be carried out with the **gun facing downwards**.

8) **NEVER** use toxic and/or explosive products with the pump.

Always check the technical details of the products and their compatibility with the machine before starting any kind of job.

9) **NEVER** use “mixed” products with this kind of pump as they may cause irreparable damages.

10) The product that is discharged during the unloading or the residues during washing **MUST NEVER** be dispersed on the ground but collected in suitable containers and disposed of in accordance with local regulations (fig. 29).

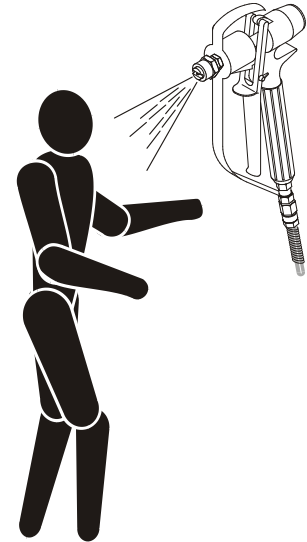

Fig.28

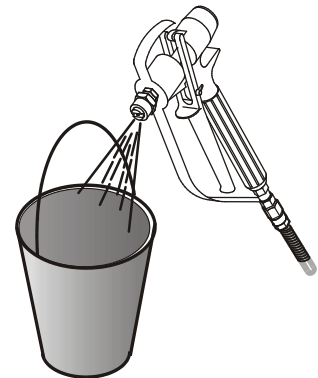

Fig.29





7.4.1 Transfers

Transfers have been put on the pump to indicate the dangerous points or warnings for the operator and technical assistants.

Before using the pump it is necessary to become familiar with the meaning of this transfer, and most of all to know exactly where they have been placed. As the transfer is adhesive it may fall off and/or deteriorate and if this was to happen they must be replaced with new transfers of exactly the same kind.

We hereby indicate the transfers placed on the pump with the meaning alongside:



 <small>Consultare sempre il manuale di uso e manutenzione</small>	WARNING	Before starting any kind of maintenance and/or regulation operation carefully read the user manual.
 <small>Mantenere la distanza dal raggio d'azione</small>	DANGER	Maintain a safety distance with regards to the ray of action of the pump.
 <small>Usare occhiali di protezione</small>	WARNING	Always wear protection goggles during use of the pump.
 <small>Usare i guanti</small>	WARNING	Always use protection gloves during work processes.
 <small>Usare la maschera</small>	WARNING	Always use a protection mask during work processes.

The above-mentioned individual safety devices must:

- be in excellent condition
- be replaced when damaged, even partially
- correspond with current regulations

Fig. 30 indicates the position in which the general plate is to be found with all details.

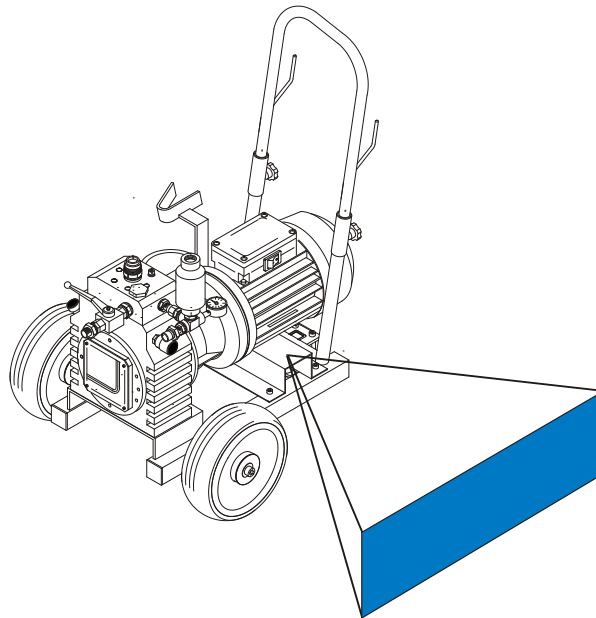

Fig.30

7.4.2 Requirements of the operator

The pump must be used **EXCLUSIVELY** by qualified personnel. An operator is considered qualified if:

- **He understands and is familiar with the written instructions, the laws and the regulations**

Written instructions by MABI include the manual and the indications written on the pump. Current laws and regulations in the country of use of the pump may require higher levels of safety requirements or may identify further risks compared with those listed in the manual.

- **He knows the conditions of use**

He must be aware of the values indicated in the technical specifications for every kind of material used. The operator must know all of the possible uses of the pump as well as the areas in which the pump must not be used.

- **He is not under the effect of drugs or alcohol**

The use of these substances may jeopardize quick reflexes and the coordination of those using the pump. An operator that uses the above-mentioned drugs must consult a doctor with regards to suitability of use for the complete safety of the pump.

- **He complies with all of the requirements necessary.**

An operator with sight or hearing problems or with slow reflexes is not considered as a qualified operator.

7.4.3 Requirements of the maintenance operators

The maintenance of the pump must be carried out **EXCLUSIVELY** by qualified personnel. An operator is considered qualified if:

- **He understands and is familiar with the written instructions, the laws and the regulations**

Written instructions by MABI include the manual and the indications written on the pump. Current laws and regulations in the country of use of the pump may require higher levels of safety requirements or may identify further risks compared with those listed in the manual.

- **He is not under the effect of drugs or alcohol**

The use of these substances may jeopardize quick reflexes and the coordination of those using the pump. An operator that uses the above-mentioned drugs must consult a doctor with regards to suitability of use for the complete safety of the pump.

7.5 Storage

The pump in operation must be correctly stored according to the estimated period of storage (temporary storage or long term storage, that is to say more than 3 months). In any case the pump should always be stored in closed areas, away from atmospheric agents (wind, rain, snow, sand etc.).

However, always apply the following suggestions:

E' bene, comunque mettere sempre in pratica i seguenti accorgimenti:

1) If the pump is not packed

- Check the state of preservation of the material after transport.
- Protect the components and the pump with pieces of polyethylene, keeping the air vents free (the polyethylene must contain additives and must support increases and decreases in temperature, humidity and light without any visible signs of decay).
- Check the protection weekly and in particular make sure the air and/or draining vents are free.

2) If the pump is packed according to special methods

- Check the state of preservation of the packaging and separate the packages according to the storage specifications indicated on them.
- Protect the loose components (if there are any) using a polyethylene cloth and check the effectiveness of the protection as indicated in the previous point.
- For the material packed in crates check the internal state of the packaging (cloth, bag etc.) and carry out subsequent controls as indicated in the previous point.

3) Installation of the stored materials

- After having removed the protection and the packages (if there are any) carry out a careful visual check of each single component and intervene, wherever necessary, to bring the materials back to their original conditions.
- Carry out functional tests, especially after a long period of storage.
- Never use the pump if any part is damaged.



Never attempt to repair the pump alone, incorrect operations may damage the operation of the pump as well as being a source of danger for the operator.

8. MAINTENANCE

8.1 Generalities

This chapter deals with all of the service procedures required to keep the pump in maximum efficiency. All of the operations indicated below must be carried out **exclusively by qualified personnel** or directly by MABI technicians. Contact specialized centers or repair centers to carry out intervention on this kind of machine.

8.2 Security regulations in terms of maintenance

Before carrying out any kind of intervention for any maintenance operation it is necessary to read carefully the contents of the manual.

The person in charge of maintenance must comply with the following, if not it may lead to serious damage.

- Using special signs indicate that maintenance work is being carried out.
- Carry out maintenance to the pump and its various components, especially the air and product pipes, and keep them in good and reliable conditions to protect your safety and to comply with current regulations.
- Never carry out maintenance intervention to the pump without instructions.
- Before carrying out any kind of maintenance intervention make sure that:
 - a) the pump is disconnected from the power supply grid
 - b) the internal pressure has been discharged
 - c) wear all of the individual safety devices previously indicated
 - d) the area in which maintenance is carried out must be suitable for such operations, in particular it must be ventilated and with sufficient lighting.
- The pump and its components must never be modified or altered and nobody must be allowed to modify or alter the pump and its components or any of its functions, without consulting the manufacturer beforehand.
- **NEVER** use free flames during maintenance operations.
- Do not smoke.
- Once intervention has been terminated, clean the area used and dispose of any materials in compliance with local regulations.

8.3 Classification of maintenance intervention

Maintenance intervention can be classified into two different types:

- Preventive maintenance: defined as the type of maintenance that is carried out to keep the pump in normal operative conditions, or be it without the need to replace parts and which includes:
 - Intervention during the first 10 hours of work
 - Daily intervention: every 10 hours
 - Weekly intervention: every 50 hours
 - Monthly intervention: every 250 hours
 - Intervention every six months: every 500 hours
 - Annual intervention: every 1,000 hours

- Extraordinary maintenance: understood as maintenance that consists of:
 - Intervention to be carried out due to breakdowns
 - Intervention to be carried out at rather long intervals, i.e. corresponding to the life limit of a primary organ and which requires an interruption in the working of the pump.

8.4 Cleaning of the pump

At the end of the working day it is very important to carry out accurate cleaning of the pump to avoid the particles of the product delivered from getting caught up inside the circuit.

In order to carry out the cleaning process, proceed as follows:

1) Lift the suction pipe and the recycle pipe from the container, making sure that the product does not fall on the ground (fig. 31).

2) Insert the suction pipe inside a bowl containing some solvent (fig. 32).

1. Suction pipe
2. Solvent

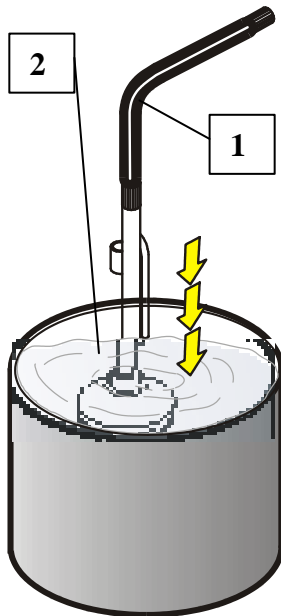

Fig.32

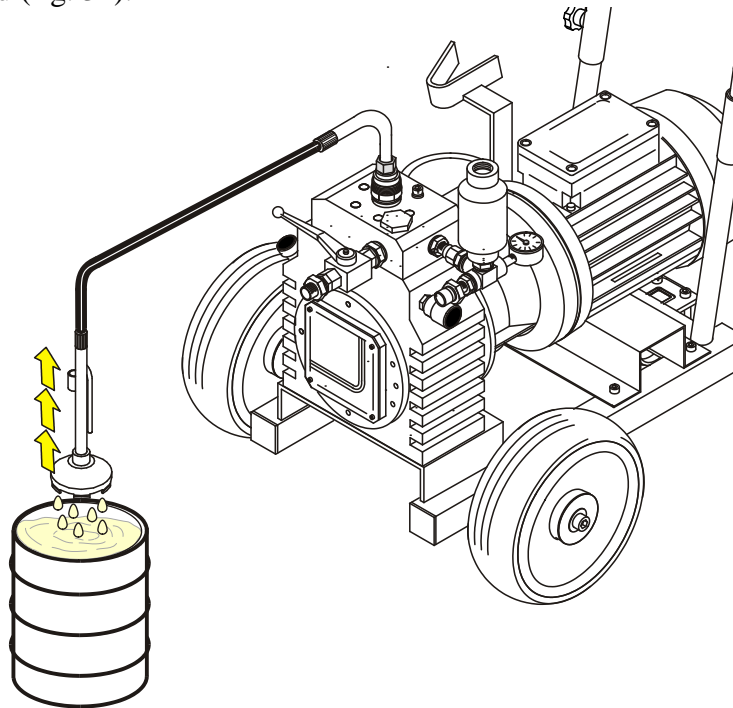

Fig.31

3) Open the discharge tap (fig. 33).

1. Suction pipe

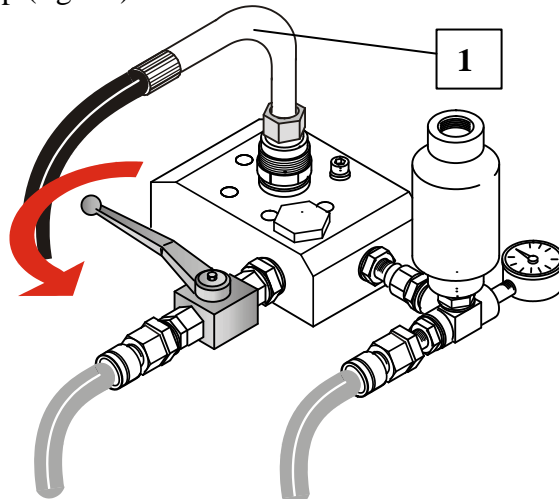
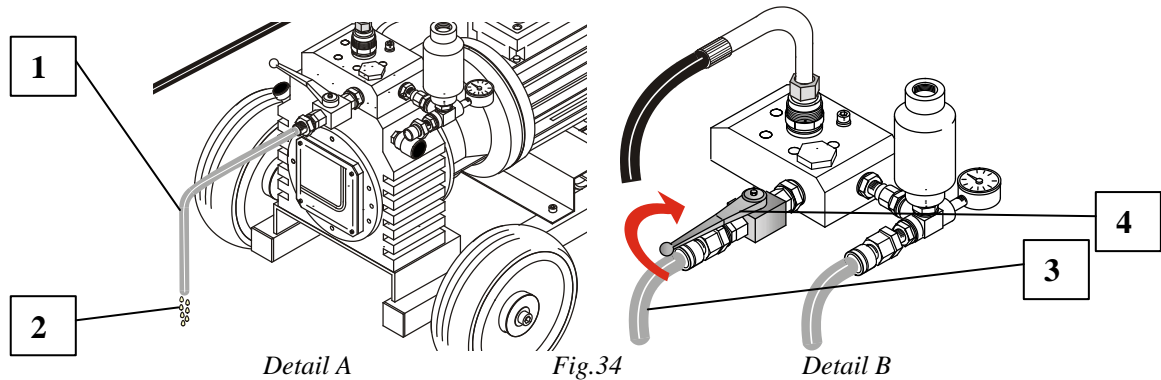

Fig.33

4) After a few seconds when there is no longer any air inside the circuit (fig.39, detail A) close the discharge tap (fig. 34, detail B).

1. Discharge pipe
2. Solvent
3. Discharge pipe
4. Discharge tap



5) Using the gun discharge any residue of the product and the solvent into a bowl (fig. 35). **Do not dispose of the product in the environment.** Carry on discharging the product until the solvent is pure.

6) Remove the filter (fig. 36) placed at the end of the suction pipe by removing the fixing spring and clean it using a solvent.

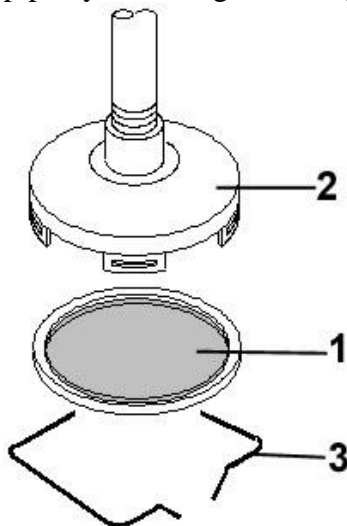
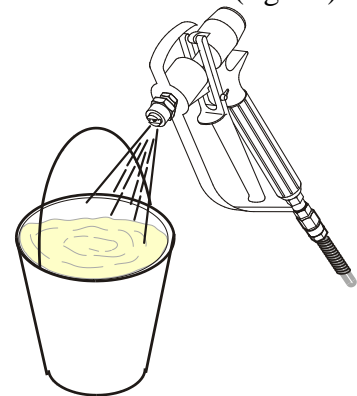

Fig.36

1. Filter
2. Suction pipe
3. Spring

8.5 Cleaning of the spray gun

Correct maintenance envisages cleaning the spray gun thoroughly every time it is used with the same pump. Keep to the following instructions.

1) Unscrew the gun handgrip (fig. 37, detail A) and remove the filter inside it (fig. 37, detail B). Clean using solvent with a brush and compressed air.

1. Spray gun handgrip
2. Spray gun filter
3. Spring

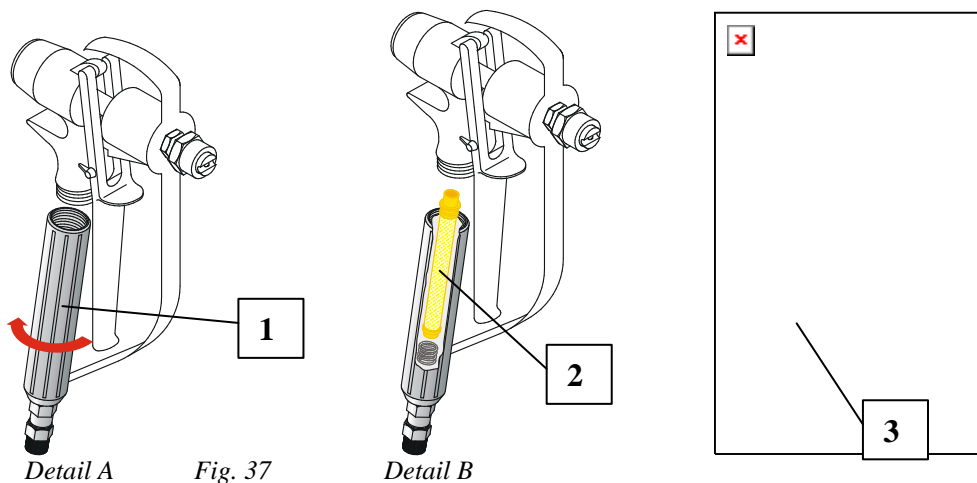

2) Remove the nozzle of the gun by loosening the screw and removing the nylon washer (fig. 38). Clean the nozzle with solvent, thinner and a brush.



Do not use pins, needles or metal brushes or similar objects that may damage the nozzle.

1. Nozzle

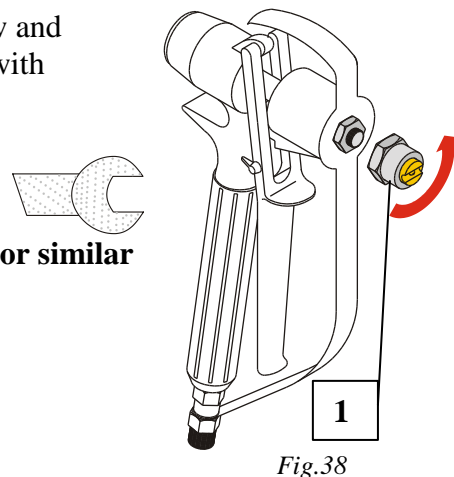

3) Replace the nozzle on the gun using the spanner provided and paying attention to the direction in which the nozzle will be spraying.
The ridge at the front of the nozzle shows the direction in which the spray fans out. To regulate nebulization of the product use the air pressure reducer.

1. Spray gun
2. Adaptable nozzles

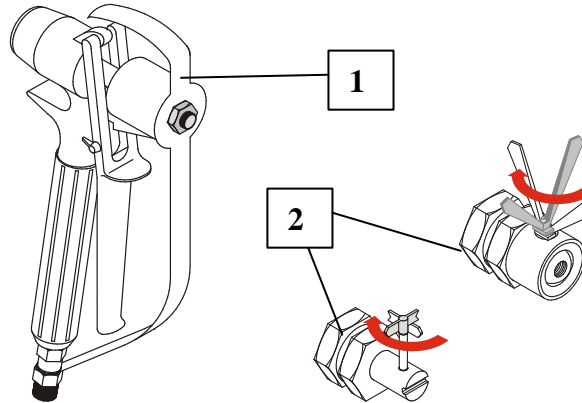

Fig.39

Important: Use the nozzle which is most suitable for the job being done and the kind of product being sprayed.

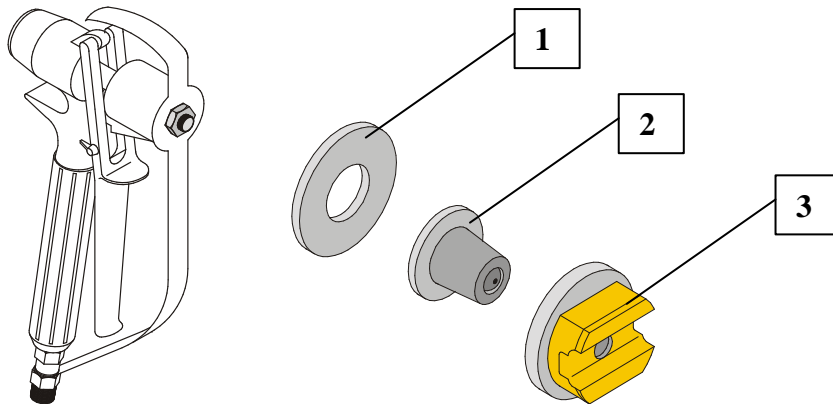

Fig.40

1. Washer
2. Nozzle
3. Ring nut

8.6 Oil change

Every now and again the oil level in the hydraulic group must be checked with the oil level cap and, if necessary, the oil must be replaced.

For a complete oil change proceed as follows:

- a) Remove the oil level cap (1, fig. 41)
- b) Unscrew the discharge cap placed under the pump casing and let the oil flow out (2, fig. 41).

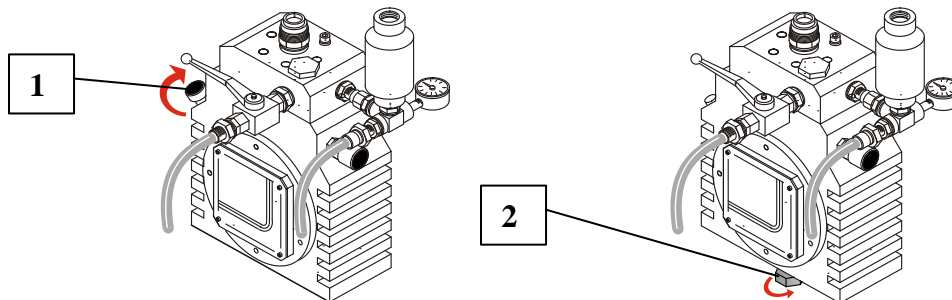

Fig.41

- c) Screw up the discharge cap and fill up with oil (fig. 42).

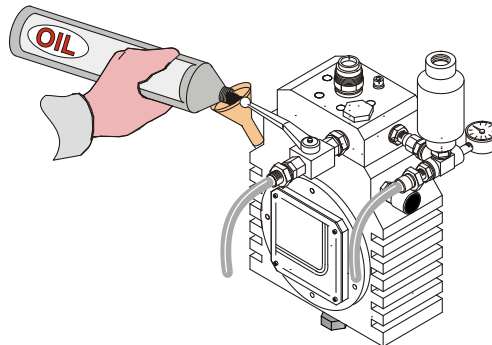

Fig.42

- d) Close oil level cap



Carry out oil changes at the following intervals:

FIRST CHANGE:	after 100 working hours
AFTER FIRST CHANGE:	every 200 working hours
OIL QUANTITY:	1 lt.
OIL TYPE:	MOBIL HTD 26 ENERGOL HLP-HM 68

8.7 Diagnosis of problems

This table provides indications of a general nature allowing for identification of any possible faults and a rapid repairs procedure.

Fault	Cause	Remedy
<p>The pump does not start</p>	<ul style="list-style-type: none"> • There is no electrical current. • Voltage is not the same as that indicated on the motor. • Control panel fuses are too weak. • Pump in emergency state. 	<ul style="list-style-type: none"> • Check mains supply. • Check voltage (220V or 380V). • Change fuses from 14A to 20A). • Use ON/OFF switch to restart.
<p>The pump does not suck up</p>	<ul style="list-style-type: none"> • The suction pipe filter is not completely emerged. • The suction pipe filter is blocked. • The suction pipe is not connected to the suction valve correctly. • The suction pipe is damaged. • The regulation valve is completely shut. • The regulation valve is blocked. • Oil level in hydraulic group is too low. • The suction valves are glued to their relative seats • The discharge tap is closed. • The delivery valve ball is blocked. 	<ul style="list-style-type: none"> • Emerge the filter completely or add more product to the container. • Clean the filter. • Fix the pipe correctly. • Replace the suction pipe. • Open the regulation valve by turning anti-clockwise. • Disassemble the regulation valve and clean. • Add oil to hydraulic group. • Remove the suction pipe and unblock the ball. • Open the discharge tap. • Stop the motor, remove the suction pipe, close the discharge tap, pour a little solvent into the suction valve and start motor again.

The pump sucks up but does not create pressure	<ul style="list-style-type: none">• The discharge tap is open.	<ul style="list-style-type: none">• Close the discharge tap and control that the product comes out from the discharge pipe.
Insufficient pressure on the gun	<ul style="list-style-type: none">• The spray gun filter is blocked.	<ul style="list-style-type: none">• Remove the spray gun filter and clean it with solvent or replace with new filter.

9. TORQUE WRENCH SETTING OF SCREWS AND BOLTS

Dxp	Preloading (N)				Torque wrench setting (Nm)			
	4.8	8.8	10.9	12.9	4.8	8.8	10.9	12.9
M4x0.7	1970	3930	5530	6640	1.5	3.1	4.3	5.2
M5x0.8	3180	6360	8950	10700	3	6	8.5	10.1
M6x1	4500	9000	12700	15200	5.2	10.4	14.6	17.5
M8x1.25	8200	16400	23100	27700	23.3	24.6	34.7	41.6
M8x1	8780	17600	24700	29600	13	26	36.6	43.9
M10x1.5	13000	26000	36500	43900	25.1	50.1	70.5	84.6
M10x1.25	13700	27400	38500	46300	26.2	52.4	73.6	88.4
M12x1.75	18900	37800	53000	63700	42.4	84.8	119	143
M12x1.25	20600	41300	58000	69600	45.3	90.6	127	153
M14x2	25800	51500	72500	86900	67.4	135	190	228
M14x1.5	28000	56000	78800	94500	71.7	143	202	242
M16x2	35200	70300	98900	119000	102	205	288	346
M16x1.5	37400	74800	105000	126000	107	214	302	362
M18x2.5	43000	86000	121000	145000	142	283	398	478
M18x1.5	48400	96800	136000	163000	154	308	434	520
M20x2.5	54900	110000	154000	185000	200	400	562	674
M20x1.5	60900	122000	171000	206000	216	431	607	728
M22x2.5	67900	136000	191000	229000	266	532	748	897
M22x1.5	74600	149000	210000	252000	286	571	803	964
M24x3	79100	158000	222000	267000	345	691	971	1170
M24x2	86000	172000	242000	290000	365	731	1030	1230
M27x3	103000	206000	289000	347000	505	1010	1420	1700
M27x2	111000	222000	312000	375000	534	1070	1500	1800
M30x3.5	126000	251000	353000	424000	686	1370	1930	2310
M30x2	139000	278000	391000	469000	738	1480	2080	2490

10. LIST OF SPARE PARTS

10.1 Group – A1097080 (EXPORT 7000/10000 pump)

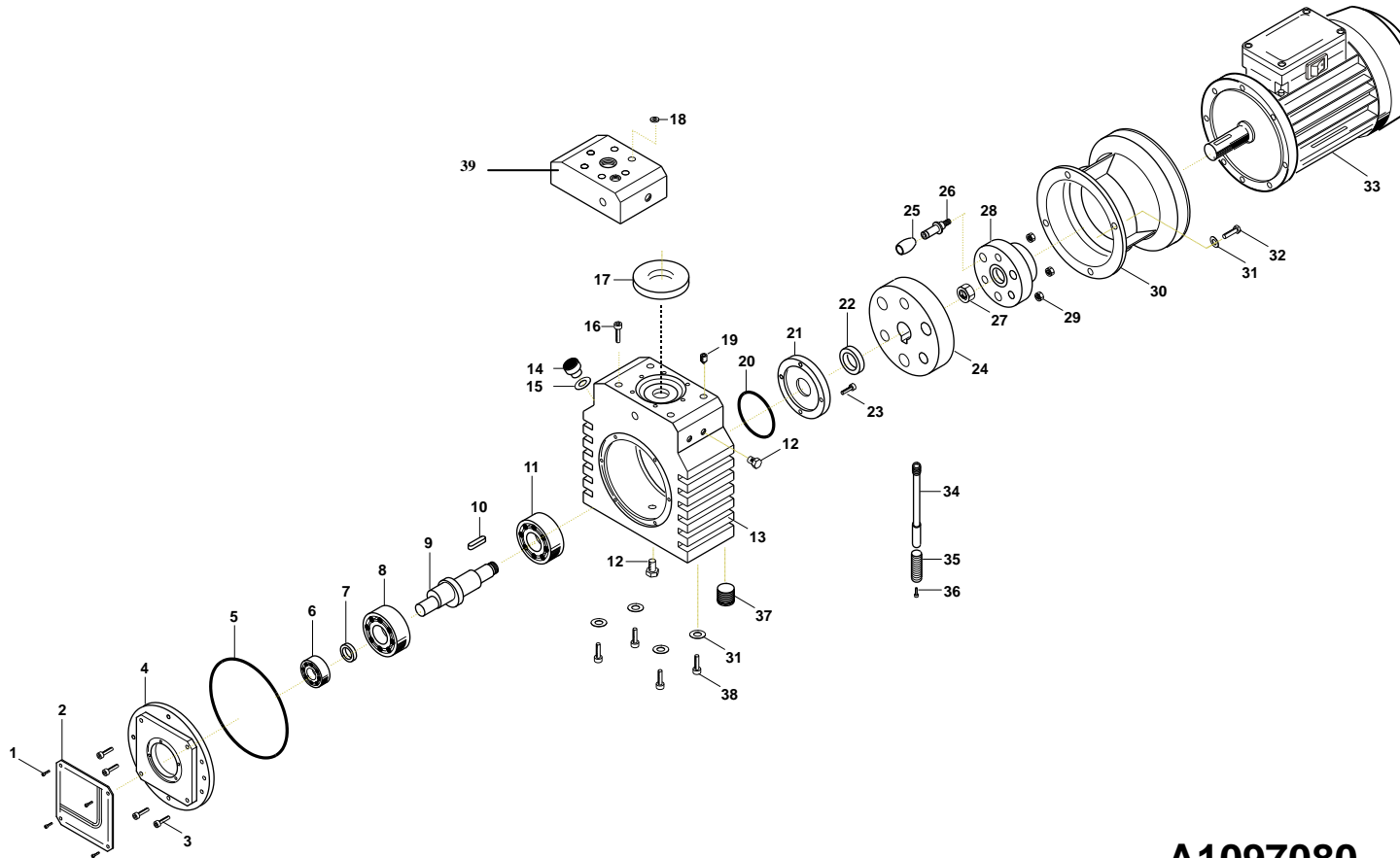

A1097080

Ref.	Code	Description	Quantity
1	RI37	3x6 rivet	4
2	013015	SM EXPORT serial number plate	1
3	101001	M6x16 galvanized socket head cap screw	4
4	013004	Front flange	1
5	012015	4600 (Ø 159.06-15x3.53) toric ring	1
6	012013	6304-2 Z bearing	1
7	132012	Ø 50 external snap ring	1
8	012014A	NUP 306 ECP bearing	1
9	013016	SM EXPORT eccentric shaft	1
10	012019	6x6x20 feather	1
11	012014	6306-2Z bearing	1
12	011001	¼ plug	2
13	013003A	EXPORT lower hydraulic group	1
14	012008	GAMM TA/2-16MB oil level cap	1
15	342025	616 o-ring	1
16	PSP6113	M10x70 (TCE UNI 5913) socket head cap screw	6
17	013048	Ø 63- Ø 30x7 teflon insert	1
18	011026	Ø 10 Ø 16.8x2.2 washer	6
19	081005	M6x10 plain dowel	1
20	012016	3287 (Ø 77,93-72,69z2,62) toric ring	1
21	013049	Ø 103,5x9 rear flange	1
22	012017	47x30x7 oil retainer	1
23	011014	M5x10 galvanized socket head cap screw	4
24	013018	Handwheel for electrical pumps	1
25	012020	20x25/8 neoprene cylindrical spring	3
26	013042	Ø 10x50 shaft	3
27	013043	M20x1x10 nut	1
28	013019	Coupling for electrical pumps	1
29	011009	M8 self-locking nut	3
30	013020	Drum for electrical pumps	1
31	011005	Ø 8 indented washer	8
32	011006	M8x20 galvanized hexagonal screw	4
33	022002	2 HP single-phase motor 220/50 (EXPORT 7000)	1
	032004	2.5 HP single-phase motor (EXPORT 10000)	1
34	013037A	Oil suction barrel	1
35	A4027074	100 mesh filter net above nozzle	1
36	101008	M6x7 galvanized cheese-headed screw	1
37	012039	Base frame shim	4
38	011027	M5x28 galvanized hexagonal screw	8
39	013007	Head for electrical pumps	1

10.2 Group – 012034C (2 HP general identification plate support)

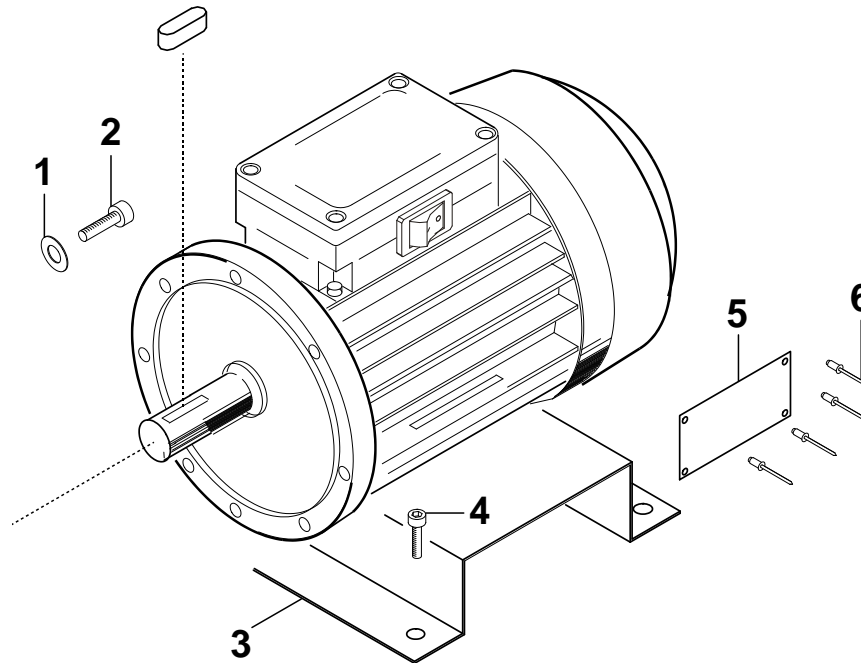

Ref.	Code	Description	Quantity
1	011010	Ø 8/18x1.5 galvanized plain washer	4
2	011027	M8x25 galvanized hexagonal screw	4
3	012034	2 HP – 3 HP – 4 HP motor plate support	1
4	312002	4x16 self-tapping screw	2
5	012035	General identification plate	1
6	RI37	3x6 rivet	4

10.3 Group – A0197045 (stainless steel suction valve for electric pumps)

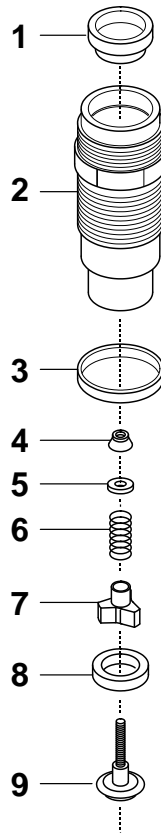

Ref.	Code	Description	Quantity
1	013046	Suction valve washer	1
2	013008	SM EXPORT suction valve casing	1
3	013045	Ø 32/28x2 suction valve washer	1
4	011012	M5 self-locking nut	1
5	011013	Ø 5/11 plain washer	1
6	013038	Ø 10x15x1 suction valve spring	1
7	013009	Obturator guide for electric pumps	1
8	013010	Ø 24/18x8 ball seat	1
9	013011	Suction valve obturator	1

10.4 Group A0197046 (complete SM-EXPORT membrane)

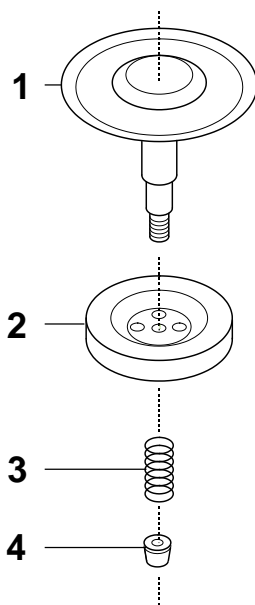

Ref.	Code	Description	Quantity
1	013050	SM-EXPORT BMNO 3x3 ATOSHEN membrane	1
2	013047	SM-EXPORT membrane support	1
3	013039	Ø 11,5x39x2 spring	1
4	013013	Ø 11 M6 membrane top	1

10.5 Group – 023003AC (EXPORT 7000 piston)

Group – 033002AC (EXPORT 10000 piston)

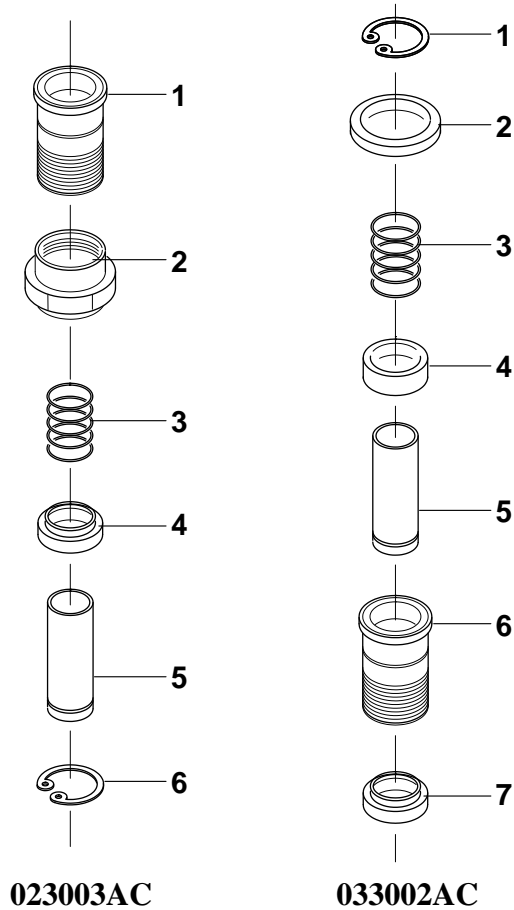

Ref.	Code	Description - 023003AC	Quantity
1	023002	EXPORT 7000 Ø 22x48 barrel	1
2	013014A	EXPORT M30x1 nut	1
3	013029	Ø 38x42x3 spring for OL91 and EXPORT	1
4	023004	Ø 38/22.5x4 for Ø 22 piston	1
5	023003A	EXPORT 7000 Ø 22x51 piston	1
6	022001	Ø 22 external snap ring	1

Ref.	Code	Description - 033002AC	Quantity
1	012022	Ø 34 internal snap ring	1
2	033003	Ø 4/16.2x5 washer	1
3	013040	Ø 19.10x55 spring	1
4	013061	EXPORT 10000 piston shim	1
5	033002A	EXPORT 10000 Ø 22x55 piston	1
6	033001	SM 8000 and EXPORT 10000 Ø 25x48 barrel	1
7	013014A	EXPORT M30x1 nut	1

10.6 Group – A0197048 (complete 1/4 discharge tap)

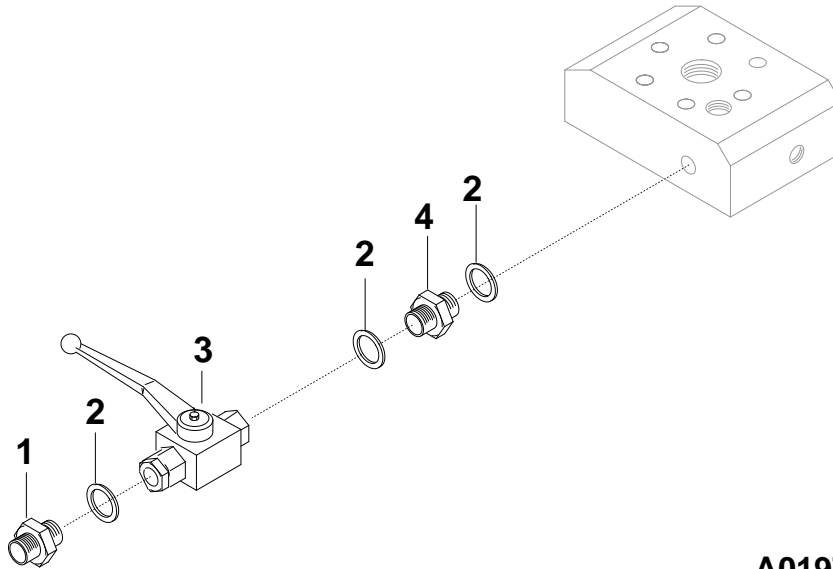

A0197048

Ref.	Code	Description	Quantity
1	014001	M20x2 1/4 nipple	1
2	011003	13x19x1.5 1/4 copper washer	3
3	014004	1/4 big tap (GE2 G1/4)	1
4	014005	1/4-1/4 nipple	1

10.7 Group – A0197051 (complete SM-EXPORT nonreturn valve)

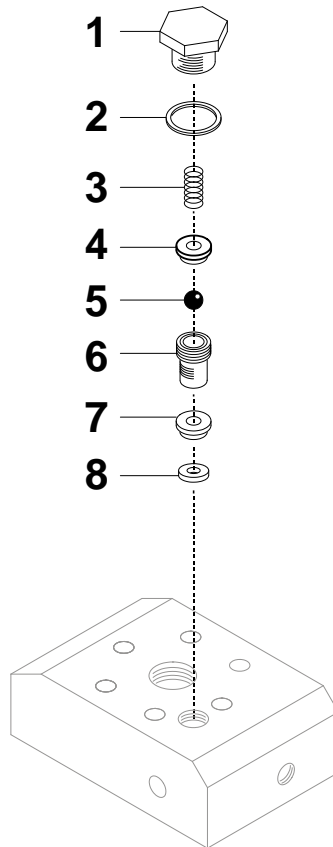

Ref.	Code	Description	Quantity
1	013032	Nonreturn valve tap	1
2	011002	Ø 22 (28x1.5) copper washer	1
3	013044	Ø 11x15x0.7 spring	1
4	012026	Support ring for spring valve	1
5	012005	Ø 11 ball	1
6	013033	Ø 16 nonreturn valve casing	1
7	013034	Ø 16 ball seat	1
8	013035	Ø 20x2 nylon washer	1

10.8 Group – 012007C (EXPORT pressure gauge)

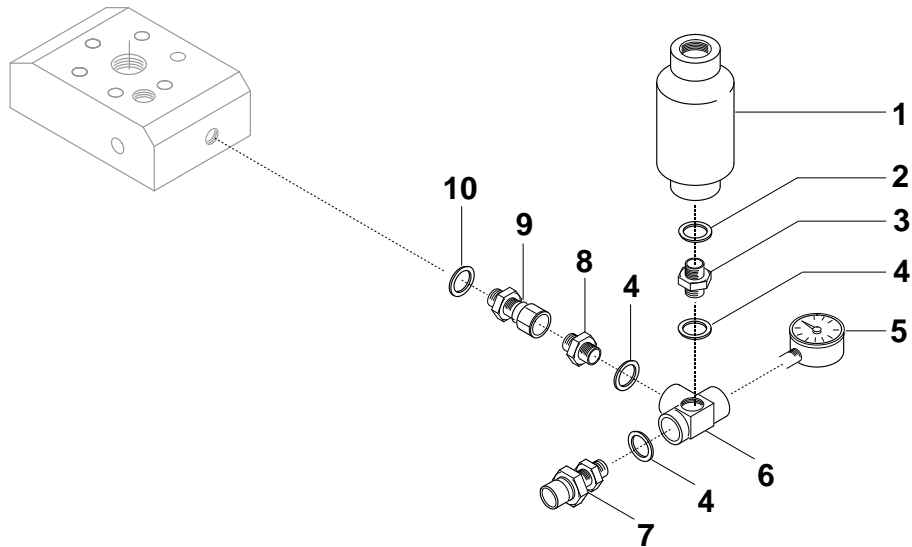

Ref.	Code	Description	Quantity
1	A4027251	H100-90 bar simple accumulator	1
2	101017	Ø 18/22 copper washer	1
3	014002	18x1.5 ¼ nipple	1
4	011003	13x19x1.5 ¼ copper washer	3
5	012007	0:400 rad. ¼ /63 pressure gauge	1
6	013036T	¼ gauge block 4 accumulator outlets	1
7	014005	¼-¼ nipple	1
8	014008	M16x1.5 ¼ adapter	1
9	014006	16x1.5 nipple	1
10	011011	⅜ copper washer	1

10.9 Group – A0197047 (complete SM-EXPORT pressure regulation valve)

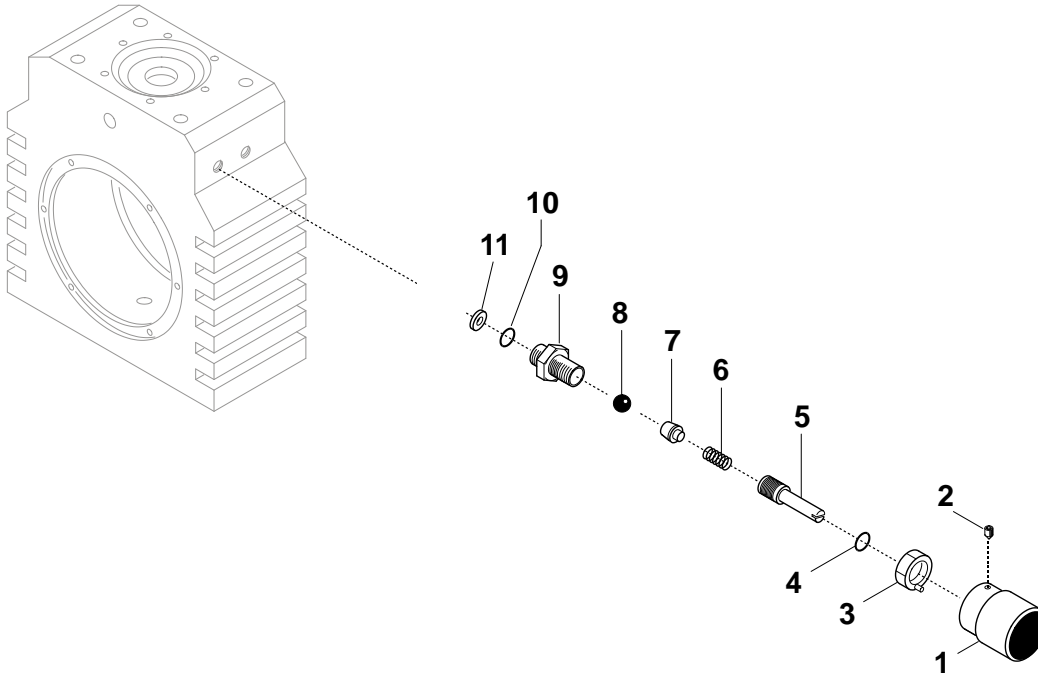

Ref.	Code	Description	Quantity
1	013012	Pressure regulation valve knob	1
2	101007	M5x10 dowel with stainless steel point	1
3	013022	Pressure regulation valve plug	1
4	012024	114 (Ø 11.11x1.78x14.67) toric ring	1
5	013021	Pressure regulation valve shaft	1
6	013041	Ø 7.5x15x1.5 regulation valve spring	1
7	013053	Pressure regulation valve ball support	1
8	012027	1/5 ball	1
9	013023	Pressure regulation valve casing	1
10	012006	2037 (Ø 12.8x9.25x1.78) (611) toric ring	1
11	013052	1/8 ball seat	1

10.10 Group – C5502 (complete big trolley for electric pumps)

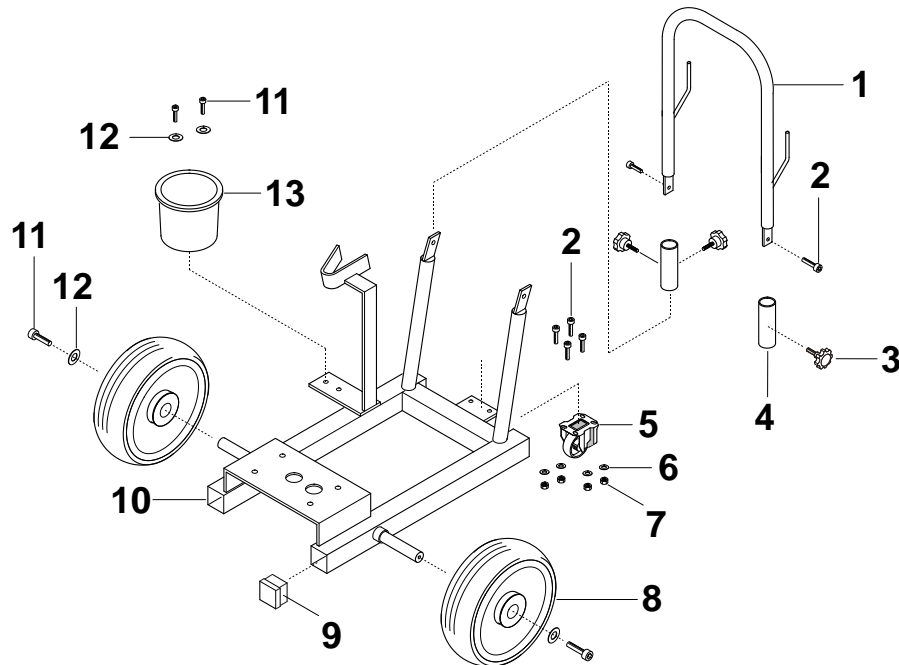

Ref.	Code	Description	Quantity
1	023001A	Ø 25 trolley handgrip	1
2	101001	M6x16 galvanized socket head cap screw	6
3	092010	M8x10 knob	2
4	013001	Trolley blocking tube	2
5	012025	Ø 80x22 H 106 rotating small wheel	1
6	PSP6090	Ø 6-Ø 12 galvanized washer	4
7	091003	M6 self-locking nut	4
8	012001	Pneumatic wheel Ø 260x85 electric pumps	2
9	012038	40x40 square rubber	4
10	013002	Big trolley base frame	1
11	PSP6136	M6x10 galvanized socket head cap screw	4
12	PSP6094	Ø 6-Ø 24x2 plain washer	4
13	083001	Sieve support	1

11. WIRING DIAGRAM

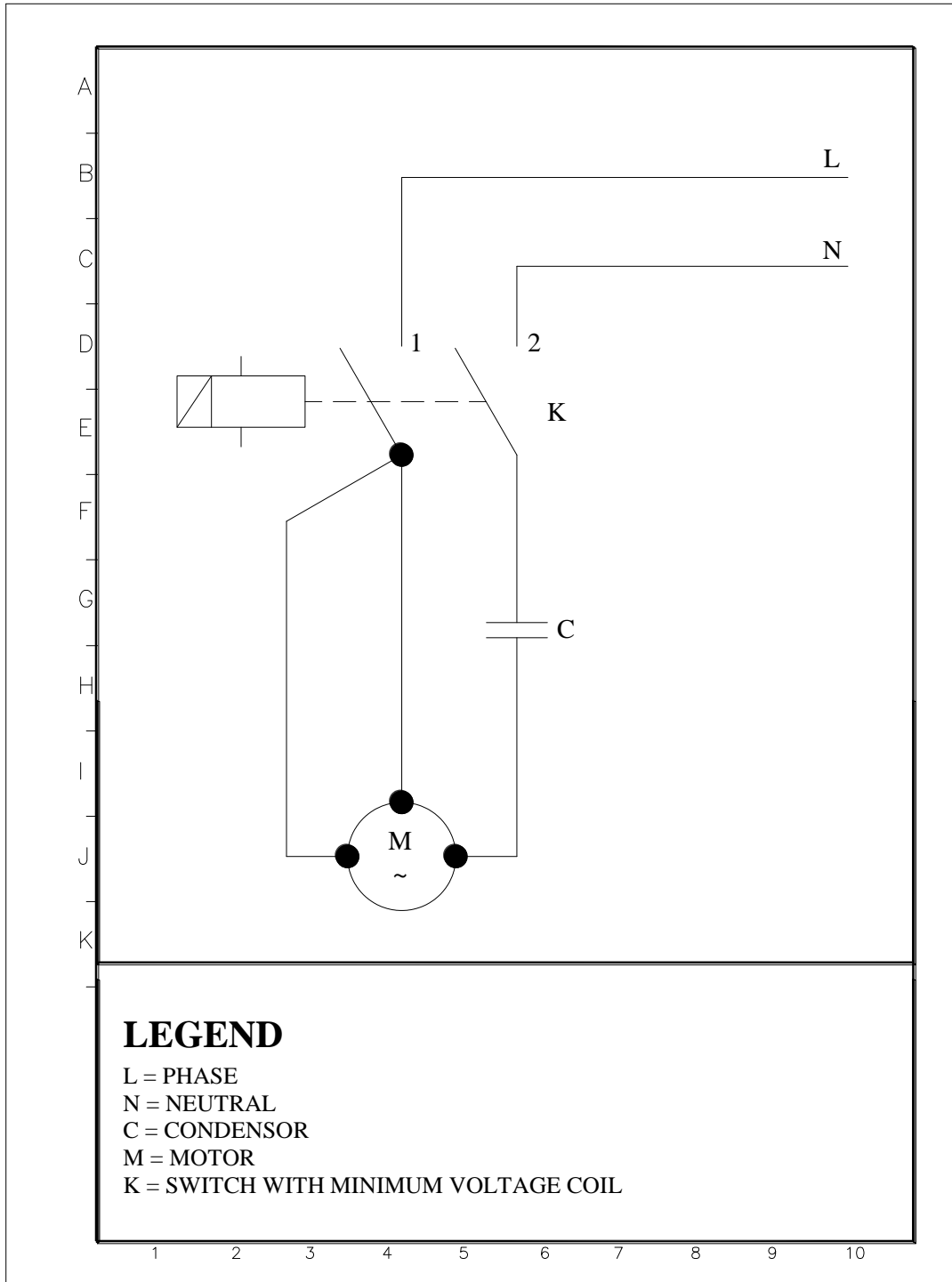

12. WARRANTY

INSTRUCTIONS UPON DELIVERY

Upon delivery of the pump Sales Organization Personnel must provide the Customer with initial detailed instructions on installation, use and maintenance.

These instructions are the ones listed below:

IMPORTANT:

During this explanation the Customer should put a cross alongside the instructions received.

- Inform the Customer about the safety regulations to be followed. Such regulations are indicated on the adhesives applied to the pump casing and the User and Maintenance manual.
- Warn the Customer that it is very important to read carefully and to understand the User and Maintenance manual before installing or starting the pump. This manual contains the main instructions related to installation, the use and the maintenance of the pump.
- Train the Customer on how to install the pump correctly.
- Train the Customer on the correct use of the pump and any accessories connected to the same, indicating the various safety devices.
- Illustrate the chapter of the manual that refers to maintenance. It is very important to explain that regular maintenance guarantees the correct operation and long life of the pump.
- With the manual train the Customer on the various stages of maintenance, highlighting the risks that may arise in this stage.
- Help the Customer to fill in the table and the warranty certificate. Once this certificate has been completed it must be sent to the Manufacturer.

MABI (hereinafter called the “Manufacturer”) guarantees that none of its new products have production and material faults when they leave the production plant. The manufacturer undertakes to replace any pieces free of charge returned due to effective material and/or production faults.

This guarantee is valid for 12 (twelve) months from the date of delivery to the Customer. In this sense, the date indicated on the invoice indicating delivery to the first User, as well as payment within the period of time established, will be considered valid.

In order to benefit from the guarantee it is vital that:

- **The first User sends the “Warranty Certificate” to the Manufacturer within 10 (ten) days upon receipt of the pump. The “Warranty Certificate” can be found inside this manual and must be filled out in all parts before the User sends it to the Manufacturer.**
- **The faulty pieces must be sent to the Manufacturer’s production plant for relative tests to be carried out, free of any charges etc. and together with the identification data indicated on the plate applied to the pump.**
- **The programs and maintenance operation times provided for by the Manufacturer, indicated in the chapter “USE AND MAINTENANCE” of the present manual, must be respected.**

Transport costs of the pieces replaced and any possible intervention by our technicians required to ascertain the causes of the fault will be borne by the User. The examination for faults and their causes may be carried out exclusively by staff of the Manufacturer or technicians assigned by the same.

The pieces replaced under the warranty will remain the property of the manufacturer.

The warranty does not cover:

- components not directly produced by the manufacturer and for which the respective manufacturer will be responsible
- faults deriving from normal use
- faults brought about by the incorrect use according to the specifications of the chapter “INCORRECT USE”
- faults due to negligence, accidents, impatience in the use and incorrect use according to the indications and the normal destination of the pump
- damages deriving from the pump being out of use for too long
- damages produced by people, things or animals following faults.

Warranty:

WARRANTY CERTIFICATE		RETAILERS' STAMP 
TYPE	_____	
SERIAL NUMBER	_____	
DELIVERY DATE	_____	
CLIENT	_____	
ADDRESS	_____	
P.C.	TOWN	(PROV.)
_____	_____	_____
CLIENT'S SIGNATURE		
<small>(Spedire al Costruttore entro 10 giorni dalla data di consegna).</small>		

